

*Design Guide*

No. 110, 4/98

L00002

# *Eclipse RatioMatic Burners*

*RM Series Version 3.00*

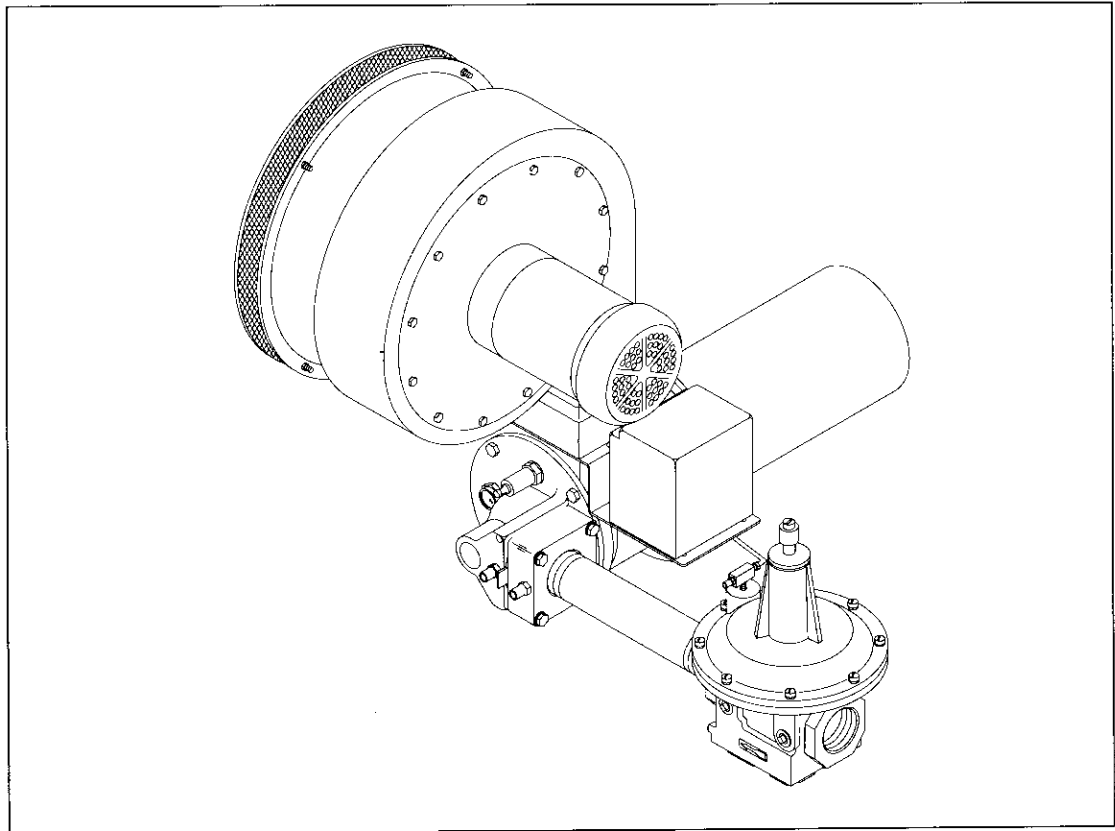

**Eclipse**

*Eclipse Combustion*

## **COPYRIGHT**

Copyright 1998 by Eclipse Combustion, Inc. All rights reserved worldwide. This publication is protected by federal regulation and shall not be copied, distributed, transmitted, transcribed or translated into any human or computer language, in any form or by any means, to any third parties, without the express written consent of Eclipse Combustion, Inc., Rockford, Illinois, U.S.A.

## **DISCLAIMER NOTICE**

We reserve the right to change the construction and/or configuration of our products at any time without being obliged to adjust earlier supplies accordingly.

The material in this manual is believed adequate for the intended use of the product. If the product, or its individual modules or procedures, are used for purposes other than those specified herein, confirmation of their validity and suitability must be obtained. Eclipse Combustion, Inc. warrants that the material itself does not infringe any United States patents. No further warranty is expressed or implied.

We have made every effort to make this manual as accurate and complete as possible. Should you find errors or omissions, please bring them to our attention so that we may correct them. In this way we hope to improve our product documentation for the benefit of our customers. Please send your corrections and comments to our Documentation Manager.

## **LIABILITY AND WARRANTY**

It must be understood that Eclipse Combustion's liability for its products, whether due to breach of warranty, negligence, strict liability, or otherwise, is limited to the furnishing of such replacement parts and Eclipse Combustion will not be liable for any other injury, loss, damage or expenses, whether direct or consequential, including but not limited to loss of use, income of or damage to material arising in connection with the sale, installation, use of, inability to use or the repair or replacement of Eclipse Combustion's products.

Any operation expressly prohibited in this Guide, any adjustment, or assembly procedures not recommended or authorized in these instructions shall void the warranty.



# *About this manual*

## **AUDIENCE**

This manual has been written for people who are already familiar with all aspects of a nozzle-mix burner and its add-on components, also referred to as “the burner system.”

These aspects are:

- design/selection
- use
- maintenance.

The audience is expected to have had experience with this kind of equipment.

## **RATIOMATIC DOCUMENTS**

### **Design Guide No. 110**

- This document

### **RatioMatic Data Sheets, Series 110**

- Available for individual RM models
- Required to complete design & selection

### **Installation Guide No. 110**

Used with Data Sheet to complete installation

### **RatioMatic Price List No. 110**

Used to order burners

## **RELATED DOCUMENTS**

- EFE 825 (Combustion Engineering Guide)
- Eclipse Bulletins and Info Guides: 710, 732, 742, 760, 818, 832, 852, 854, 856, 610, 620, 630, 826, 820, 930, I-354.

### **Purpose**

The purpose of this manual is to ensure that the design of a safe, effective, and trouble-free combustion system is carried out.

## DOCUMENT CONVENTIONS

There are several special symbols in this document. You must know their meaning and importance.

The explanation of these symbols follows below. Please read it thoroughly.



### **Danger:**

**Indicates hazards or unsafe practices which WILL result in severe personal injury or even death. Only qualified and well trained personnel are allowed to carry out these instructions or procedures.**

**Act with great care and follow the instructions.**



### **Warning:**

**Indicates hazards or unsafe practices which could result in severe personal injury or damage.**

**Act with great care and follow the instructions.**



### **Caution:**

*Indicates hazards or unsafe practices which could result in damage to the machine or minor personal injury, Act carefully.*



### **Note:**

*Indicates an important part of the text. Read thoroughly.*

## HOW TO GET HELP

If you need help, contact your local Eclipse Combustion representative. You can also contact Eclipse Combustion at any of the addresses listed on the back of this document.

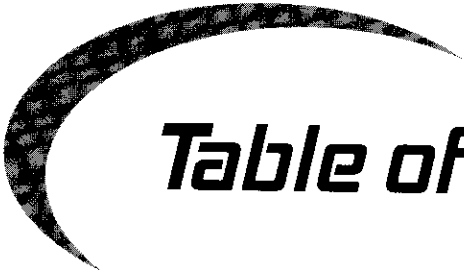

# *Table of Contents*

	<b>About this manual</b> .....	ii
	Audience .....	iii
	RatioMatic Documents .....	iii
	Related Documents .....	iii
	Document Conventions .....	iv
	How to Get Help .....	iv
	<b>Table of Contents</b> .....	v
<b>1</b>	<b>Introduction</b> .....	1-1
	Product Description .....	1-1
<b>2</b>	<b>Safety</b> .....	2-1
	Capabilities .....	2-2
	Operator Training .....	2-2
	Replacement Parts .....	2-2
<b>3</b>	<b>System Design</b> .....	3-1
	Design .....	3-1
	Step 1: Burner Option Selection .....	3-2
	Step 2: Blower Option Selection .....	3-4
	Step 3: Control Methodology .....	3-5
	Step 4: Ignition System .....	3-6
	Step 5: Flame Monitoring Control System .....	3-8
	Step 6: Main Gas Shut-Off Valve Train .....	3-9
	<b>Appendix</b> .....	A-1
	Conversion Factors .....	A-1
	Key to System Schematics .....	A-2



# Introduction

# 1

## PRODUCT DESCRIPTION

The RatioMatic Version 3.00 is a nozzle-mix type burner designed for direct air heating, indirect air heating, and oven applications up to 1800° F. (1000° C.)

The burner package includes a combustion air blower and an air:gas ratio regulator to fire over a wide gas turndown range at a controlled ratio.

The burner is designed for:

- efficient ratio controlled combustion
- reliable burner operation
- simple burner adjustment
- direct spark ignition
- multiple fuel capability

A wide variety of options and configurations are available due to the modular design of the burner.

### The RatioMatic Burner

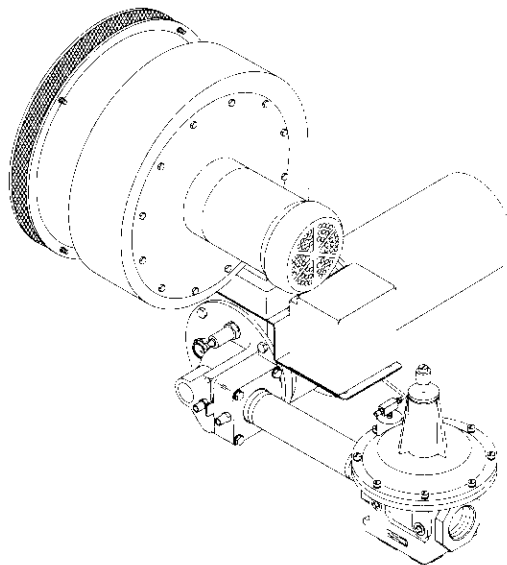



# 2

## INTRODUCTION

## SAFETY

This section is provided as a guide for the safe operation of the RatioMatic burner system. All involved personnel should read this section carefully before operating this system.



### **Danger:**

The RatioMatic burners, described herein, are designed to mix fuel with air and burn the resulting mixture. All fuel burning devices are capable of producing fires and explosions if improperly applied, installed, adjusted, controlled, or maintained.

Do not bypass any safety feature; fire or explosion could result.

Never try to light a burner if it shows signs of damage or malfunction.



### **Warning:**

The burner might have **HOT** surfaces. Always wear protective clothing when approaching the burner.



### **Note:**

*This manual provides information in the use of these burners for their specific design purpose. Do not deviate from any instructions or application limits described herein without written advice from Eclipse Combustion.*

*Read the entire manual before attempting to start this system. If you do not understand any part of the information contained in this manual, contact your local Eclipse representative or Eclipse Combustion before continuing.*

## **CAPABILITIES**

Only qualified personnel, with good mechanical aptitude and experience on combustion equipment, should adjust, maintain, or troubleshoot any mechanical or electrical part of this system.

## **OPERATOR TRAINING**

The best safety precaution is an alert and trained operator. Train new operators thoroughly and have them demonstrate an adequate understanding of the equipment and its operation. A regular retraining schedule should be administered to ensure operators maintain a high degree of proficiency.

## **REPLACEMENT PARTS**

Order replacement parts from Eclipse Combustion only. All Eclipse Combustion approved, customer supplied valves or switches should carry UL, FM, CSA, CGA, and/or CE approval, where applicable.





# *System Design*

# **3**

## **DESIGN**

### **Design structure**

The design process is divided into the following steps:

#### **1. Burner Option Selection including:**

- Burner Model / Size Selection
- Fuel Type
- Air Supply
- Combustor Type
- Combustor Length
- Control Motor
- Burner Configuration
- Gas Pipe Connection
- Flame Supervision
- Air Flow Switch

#### **2. Blower Option Selection including:**

- Power Supply Frequency
- Pressure & Flow
- Blower Motor Type
- Blower Inlet
- Motor Orientation

#### **3. Control Methodology including:**

- Burner Control

#### **4. Ignition System including:**

- Ignition Transformer
- Trial For Ignition
- Ignition Gas Piping

#### **5. Flame Monitoring Control System including:**

- Flame Sensor
- Flame Monitoring Control

#### **6. Main Gas Shut-Off Valve Train including:**

- Component Selection
- Valve Train Size

## Step 1: Burner Option Selection

Step 1 describes how to select burner options to suit an application. Use the RatioMatic Price List 110 and Data Sheets, Series 110 when following this selection process.



### Caution:

Consult EFE-825, Eclipse Combustion Engineering Guide, or contact Eclipse Combustion if you have special conditions or questions.

### Burner Model / Size Selection

Consider the following when selecting the burner size:

- **Heat Input.** Calculate the required heat input to achieve the required heat balance.
- **Power Supply Frequency.** Burner capacity will vary with power supply frequency (50Hz or 60Hz power).
- **Combustion Chamber Pressure.** Consider the effects that large or varying chamber pressures have on burner performance.
- **Altitude.** The maximum burner capacity is reduced by approximately 3% each 1000 feet (300 meters) above sea level.
- **Combustion Air Supply.** Combustion air should be fresh (20.9% O<sub>2</sub>) and clean (without corrosives).
- **Combustion Air Temperature.** Changes in air supply temperature can affect the burner capacity. The combustion air supply temperature should not exceed 250° F.
- **Fuel Type.** Variation in calorific value and density will affect burner performance.

### Fuel Type

Fuel	Symbol	Gross Heating Value	Specific Gravity
Natural gas	CH <sub>4</sub> 90%+	1000 BTU/ft <sup>3</sup> (40 MJ/m <sup>3</sup> )	0.60
Propane	C <sub>3</sub> H <sub>8</sub>	2570 BTU/ft <sup>3</sup> (103 MJ/m <sup>3</sup> )	1.52
Butane	C <sub>4</sub> H <sub>10</sub>	3250 BTU/ft <sup>3</sup> (130 MJ/m <sup>3</sup> )	1.95

BTU/ft<sup>3</sup> @ standard conditions (MJ/m<sup>3</sup> @ normal conditions)

If using an alternative fuel supply, contact Eclipse Combustion with an accurate breakdown of the fuel components.

### Air Supply

When a standard RatioMatic Version 3.00 burner is ordered, a combustion air blower is supplied and mounted directly to the burner body.

### Combustor Type

Select a combustor type based on the application. Low temperature applications use an alloy combustion tube. High temperature applications use a silicon carbide (SiC) tube or a refractory block & holder.

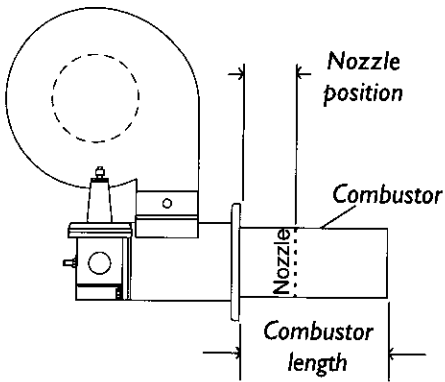

### Combustor Length

Select a combustor length. Optional lengths are available on some models. Nozzle position will vary with combustor length. The nozzle position determines the location of heat release.

### Control Motor

Select a control motor. Standard control motor options include various models which Eclipse will mount to the burner. RatioMatics can be ordered with control motor bracket and mounting hardware only. Customer supplied control motors must conform to the these specifications:

- rotation not to exceed 2 rpm.
- minimum torque of 25 in-lb. (2,8 Nm)
- 90° stroke.
- continuous modulating or high/low modulating control.
- reversible direction of rotation.
- certain applications may require control motors with a limit switch or switches if:
  - the burner capacity is to be limited to fit an application.
  - the chamber is to be fired with positive or negative pressure.
  - the chamber pressure is outside the range -1" w.c. to +1" w.c. (-2,5 to 2,5 mbar)
  - there is a need to indicate a high and/or low fire air butterfly valve (BV) position.

### Configuration selections:

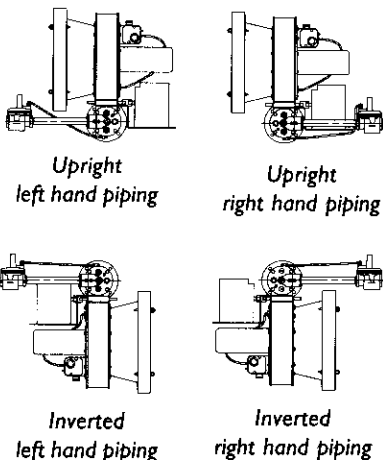

### Burner Configuration

Select configuration.

### Gas Pipe Connection

Select the gas pipe connection including the pipe thread type and the turndown required.

The piping, burner gas inlet, and ratio regulator are threaded using the customer selected pipe thread option.

The high turndown option includes a ratio regulator with an adjustment for lower inputs.

### Flame Supervision

Select a flame rod or an ultraviolet (U.V.) scanner. Both are available on all RatioMatics. If a flame rod is selected, it will be factory mounted in the burner. If a U.V. scanner is selected, it must be ordered separately.



### Warning:

A U.V. scanner could possibly detect another burner's flame if it is in the line of sight, and falsely indicate flame presence. Use a flame rod in this situation. This helps prevent accumulation of unburned fuel which, in extreme situations, could cause a fire or an explosion.

## Step 1: Burner Option Selection (continued)

## Step 2: Blower Option Selection

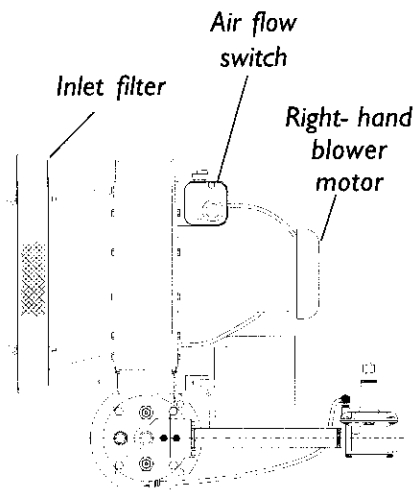

### Air Flow Switch

The air flow switch provides a signal to the monitoring system when there is not enough air pressure from the blower. If a switch is selected, it will be factory mounted.



#### **Warning:**

Eclipse Combustion supports the NFPA regulation requiring, as a minimum standard for main gas shut-off systems, the use of an air pressure switch in conjunction with other system components.



#### **Note:**

Standard blower options are listed in Price List 110, additional blower options are available through Eclipse Combustion. Price and leadtime may vary.

### Power Supply Frequency

Select the 50Hz or 60Hz option. The 50Hz blower motors have IEC frames and are CE marked. The 60Hz motors have NEMA frames.

### Pressure & Flow

RatioMatics include a combustion air blower.

### Blower Motor Type

Motor types include various options: voltages, single or three phase, TEFC or automotive duty enclosures.

### Blower Inlet

When selecting an inlet, consider the following:

- amount and size of particles in the air.
- sound requirements.
- space limitations.
- cleanliness requirements of the process.

### Motor Orientation

All RatioMatics are assembled with a right-hand blower motor orientation.

### Step 3: Control Methodology

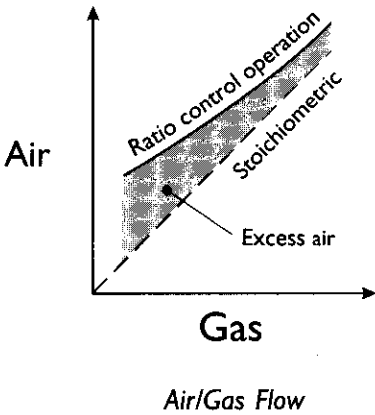

All standard RatioMatics are designed for:

- air:gas ratio controlled combustion.
- 10% to 15% excess air at high fire.
- higher excess air at low fire

### Burner Control

RatioMatics come with a ratio regulator that maintains the air:gas ratio.

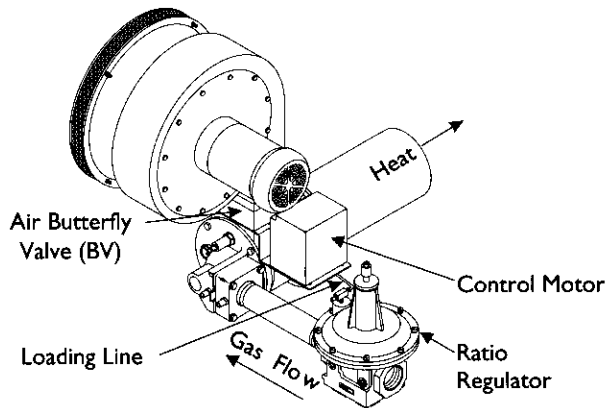

- A control signal is sent from a process temperature controller (sold separately) to the control motor. (Refer to Bulletin 818C or contact Eclipse Combustion for further information on temperature controllers.)

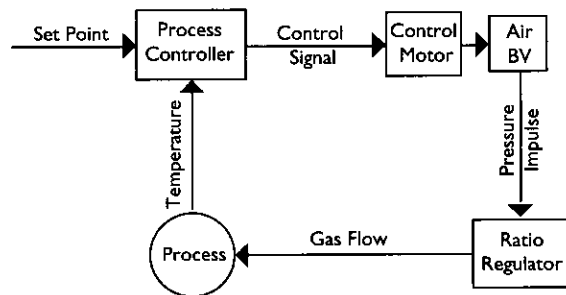

- The control motor modulates the air butterfly valve (BV) which controls the combustion air flow.
- Air pressure in the burner body sends an impulse down the loading line to the ratio regulator.
- The ratio regulator controls the gas flow in proportion to the air flow.

### Warning:



**Do not use other control methods, such as, a fixed-air control, and do not alter the ratio regulator or burner piping without prior approval from Eclipse Combustion.**

## Step 4: Ignition System

### Ignition Transformer

For the ignition system, use a transformer with:

- secondary voltage 6,000 to 8,000 VAC.
- minimum secondary current 0.02 amps continuous.
- full wave output.

DO NOT USE the following:

- twin outlet transformer
- distributor type transformer.

### Trial For Ignition

It is recommended that low fire start be used. However, under certain circumstances RatioMatics are capable of direct spark ignition at higher gas inputs.

Most local safety codes and insurance requirements limit the maximum trial for ignition time (the time it takes for a burner to ignite). These requirements vary from one location to another; check your local codes and comply to the strictest codes applicable.

The time it takes for a burner to ignite depends on the following:

- the distance between the gas shut-off valve and the burner.
- the air/gas ratio.
- the gas flow conditions at start-up.

The possibility exists where the low fire is too low to ignite the burner within the maximum trial for ignition time. The following options must be considered under these conditions:

- start at higher gas input levels.
- resize and/or relocate the gas controls.
- use bypass start gas.

## Step 4: Ignition System (continued)

### Ignition Gas Piping

RatioMatics are capable of ignition with either low fire or bypass start gas.

#### Low Fire Start:

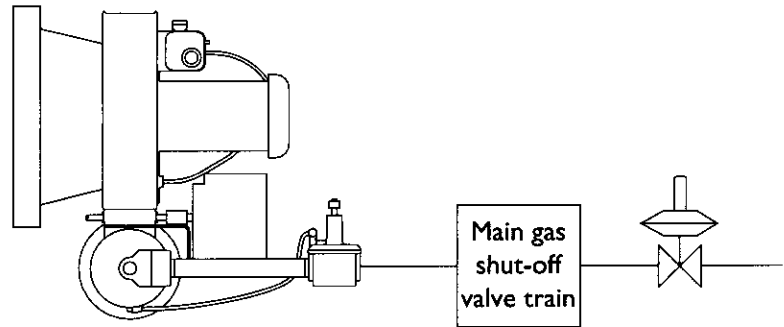

#### Bypass Start Gas (optional):

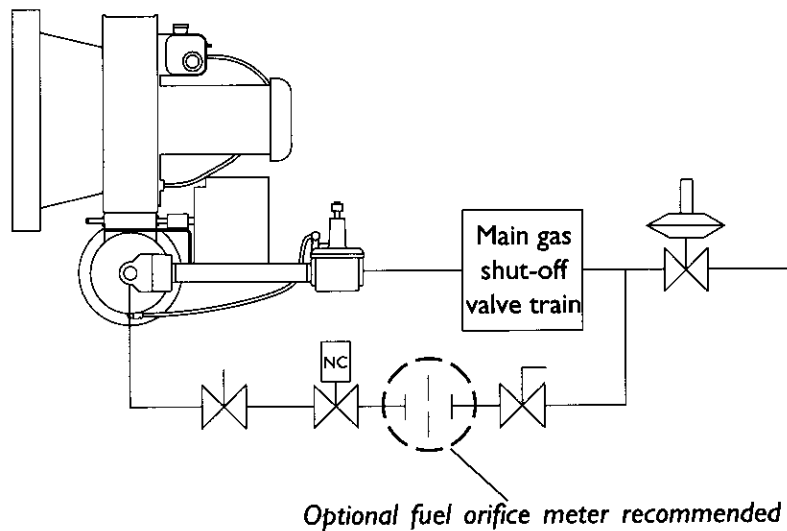

An optional fuel orifice meter connected in the start gas piping can simplify start-up and adjustment. To start the burner at the lowest possible gas input, select a fuel orifice meter for 5" to 10" w.c. pressure drop when the gas flow is at the burner's rated low fire.

## Step 5: Flame Monitoring Control System

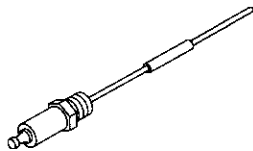

Flame Rod

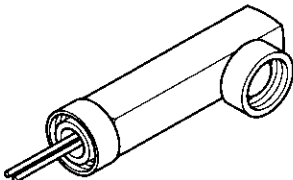

U.V. Scanner

The flame monitoring control system consists of two main components:

- Flame Sensor
- Flame Monitoring Control

### Flame Sensor

Two types can be used on a RatioMatic Burner:

- flame rod
- U.V. scanner

Flame rods are available for all RatioMatic Burner sizes. Further information can be found in:

- Info Guide 832

A U.V. scanner can be used on all RatioMatic Burner sizes.

Further information can be found in:

- Info Guide 852; 90° U.V. scanner
- Info Guide 854; straight U.V. scanner
- Info Guide 856; self-check U.V. scanner

### Flame Monitoring Control

The Flame Monitoring Control processes the signal from the flame rod, or U.V. scanner, and controls the start-up sequence and the main gas shut-off valve sequence.

Eclipse Combustion recommends the use of flame monitoring control systems which maintain a spark for the entire trial for ignition time when using U.V. scanners. Some of these flame monitoring models are:

- Veri-Flame; see Bulletin / Info Guide 610, 620, 630
- Bi-Flame series; see Instruction Manual 826
- Multi-Flame series 6000; see Instruction Manual 820

### DO NOT USE:

- PCI Automatic flame monitoring
- Honeywell RM7890 series flame monitoring
- Flame monitoring relays which interrupt the trial for ignition when the flame is detected.
- Flame sensors which supply a weak signal.
- Flame monitoring relays with low sensitivity.



## Step 6: Main Gas Shut-Off Valve Train

### Component Selection

Eclipse Combustion can help in the design of a main gas shut-off valve train that satisfies the customer and complies with all local safety standards and codes set by the authorities within that jurisdiction. Contact Eclipse Combustion for further information.



Note:

*Eclipse Combustion supports NFPA regulations (two gas shut-off valves as a minimum standard for main gas shut-off systems).*

### Valve Train Size

Fuel pressure supplied to the ratio regulator inlet must be within the range specified in the RatioMatic data sheet. The valve train should be sized sufficiently to provide the specified pressure.



Warning:

**Do not operate RatioMatics with gas inlet pressure less than the minimum listed on the RatioMatic Data Sheet. Lower gas inlet pressures may cause the ratio regulator to remain fully open at lower inputs as the burner transitions from low to high fire. This could result in the possible accumulation of unburned fuel in the burner which, in extreme situations, could cause a fire or an explosion.**



# Appendix

## CONVERSION FACTORS

### Metric to English.

From	To	Multiply By
cubic meter (m <sup>3</sup> )	cubic foot (ft <sup>3</sup> )	35.31
cubic meter/hour (m <sup>3</sup> /h)	cubic foot/hour (cfh)	35.31
degrees Celsius (°C)	degrees Fahrenheit (°F)	(°C × 1.8) + 32
kilogram (kg)	pound (lb)	2.205
kilowatt (kW)	BTU/hr	3414
meter (m)	foot (ft)	3.28
millibar (mbar)	inches water column ("w.c.)	0.401
millibar (mbar)	pounds/sq in (psi)	14.5 × 10 <sup>-3</sup>
millimeter (mm)	inch (in)	3.94 × 10 <sup>-2</sup>
MJ/m <sup>3</sup> (normal)	BTU/ft <sup>3</sup> (standard)	2.491 × 10 <sup>-2</sup>

### Metric to Metric.







kiloPascals (kPa)	millibar (mbar)	10
meter (m)	millimeter (mm)	1000
millibar (mbar)	kiloPascals (kPa)	0.1
millimeter (mm)	meter (m)	0.001

### English to Metric.

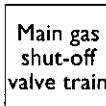
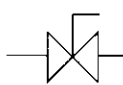
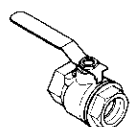
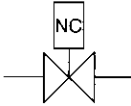
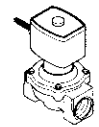
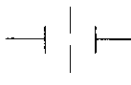

From	To	Multiply By
BTU/hr	kilowatt (kW)	0.293 × 10 <sup>-3</sup>
cubic foot (ft <sup>3</sup> )	cubic meter (m <sup>3</sup> )	2.832 × 10 <sup>-2</sup>
degrees Fahrenheit (°F)	degrees Celsius (°C)	(°F - 32) ÷ 1.8
foot (ft)	meter (m)	0.3048
inches (in)	millimeter (mm)	25.4
inches water column ("wc)	millibar (mbar)	2.49
pound (lb)	kilogram (kg)	0.454
pounds/sq in (psi)	millibar (mbar)	68.95
BTU/ft <sup>3</sup> (standard)	MJ/m <sup>3</sup> (normal)	40.14

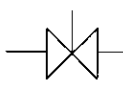
**KEY TO SYSTEM  
SCHEMATICS**

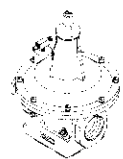
These are the symbols used in the schematics.

Symbol	Appearance	Name	Remarks	Bulletin/ Info Guide
		RatioMatic		
		Main Gas Shutoff Valve Train	Eclipse Combustion, Inc. strongly endorses NFPA as a minimum	756
		Gas Cock	Gas cocks are used to manually shut off the gas supply on both sides of the main gas shut-off valve train.	710
		Solenoid Valve (normally closed)	Solenoid valves are used to automatically shut off the gas supply on a bypass gas system or on small capacity burners.	760
		Fuel Orifice Meter	Fuel orifice meters are used to measure gas flow.	910
		Adjustable Limiting Orifice	Adjustable limiting orifices are used for fine adjustment of gas flow.	
		Pressure Regulator	A pressure regulator reduces gas pressure to a stable, usable pressure.	684
		Ratio Regulator	A ratio regulator is used to control the air/gas ratio. The ratio regulator is a sealed unit that adjusts the gas flow in ratio with the air flow. To do this, it measures the air pressure with a pressure sensing line, the impulse line. This impulse line is connected between the top of the ratio regulator and the burner body.	742

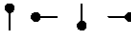
**KEY TO SYSTEM  
SCHEMATICS (CONTINUED)**

Symbol	Appearance	Name	Remarks	Bulletin/ Info Guide
		Pressure Taps		
		Impulse Line		



**Offered By:**

Power Equipment Company  
2011 Williamsburg Road  
Richmond, Virginia 23231  
Phone (804) 236-3800  
Fax (804) 236-3882

---

[www.peconet.com](http://www.peconet.com)